



PATCO® D9180
FR Aircraft Waterseal Tape & Corrosion Inhibitor

APPLICATIONS

- Aircraft waterseal applications in main cabin areas including galleys, entryways, lavatories and any areas that are susceptible to moisture damage.
- Surface protection and sound dampening.
- Meets FAR 25.853(a) Appendix F for interior aircraft use.

FEATURES & BENEFITS

- Pressure sensitive, repositionable, flame retardant, and sealant compatible.
- Tough and durable.
- Moisture resistant.
- Helps prevent corrosion on floor structure.
- Easy and fast to apply.
- Meets all interior FR requirements.
- Can be applied directly over wet sealant.
- Transparent to allow for visual inspection.
- Release liner for wide width usage and die-cuts.

CONSTRUCTION

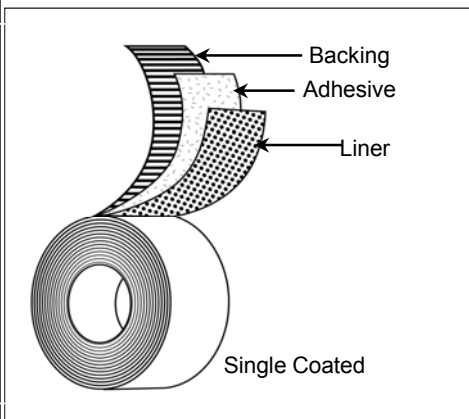

PRODUCT DESCRIPTION

Single-Coated w/Liner Construction

Backing:

- Interior-Grade Aromatic Polyurethane

Adhesive:

- Urethane-Based

Liner:

- 92# Coated Kraft Paper

Colors:

- Transparent

TEST DATA

Test	Typical Value	Typical Value (Metric)	Test Method
Total Thickness	14 mils	0.356 mm	PSTC-33
Substrate Thickness	12 mils	0.304 mm	PSTC-33
Adhesion to Steel	45 oz./in.	50.4 g/mm	ASTM D-3330
Tensile Strength	100 lb./in.	1.79 kg/mm	ASTM D-3759
Elongation (%)	600 %		
Operating Temperature	-65F to 300F	-54°C to 148°C	
Application Temperature	50F to 120F	10°C to 49°C	
Weight	1.415 oz/ft ²		
Shelf Life @ 25° C (77° F)**	24 Months		

**Recommended storage conditions: 40-60% Humidity, 60 °F - 80 °F

The information presented herein was prepared at BERRY PLASTICS CORPORATION (25 Forge Parkway Franklin, MA 02038) by qualified technical personnel. To Berry Plastics' knowledge it is true and accurate. However, the information and recommendations are furnished for these products with the understanding that the purchaser or user, as the case may be, will independently determine that the product is suitable for the intended use, and that such use complies with all applicable federal, state and local laws and regulations. The data are submitted only for the user's information and consideration, and do not constitute a warranty of any kind (including but not limited to a warranty of merchantability or of fitness for a particular purpose), or a representation for which BERRY PLASTICS assumes any legal responsibility.

For Pricing and Information

please contact distributor:

KIEPURA AVIATION CORP.

61 Church St.

Littleton, NH 03561

Tel: 603-444-3459 / Fax: 603-444-0790

Toll Free: 1-888-522-8273 (USA/Canada)

Email: jane@kiepuraaviation.com

www.kiepuraaviation.com